

V O L V O P E N T A

ANODES

Genuine Volvo Penta sacrificial anodes



Genuine Volvo Penta sacrificial anodes

Genuine Volvo Penta anodes are made to sacrifice themselves in order to protect your drive and propeller from galvanic corrosion. Volvo Penta now recommends the use of Aluminum anodes in salt and brackish water instead of zinc for salt water as previously recommended. Volvo Penta will gradually phase out and replace most of our zinc anodes with aluminum anodes.

Aluminum anodes provide:

- 30% higher corrosion protection capacity
- up to 20-40% longer life span in salt water, compared with similarly-sized zinc anodes
- lower environmental impact
- better choice also for brackish water

Volvo Penta has worked and invested intensively in the aluminum alloy manufacturing processes and quality control system, resulting in a high degree of purity of the alloy.

When installing a new anode it is important to have good contact between the anode and the surface to which it is connected. Read the Operator's Manual for detailed information regarding maintenance and replacing anodes for your Volvo Penta product.

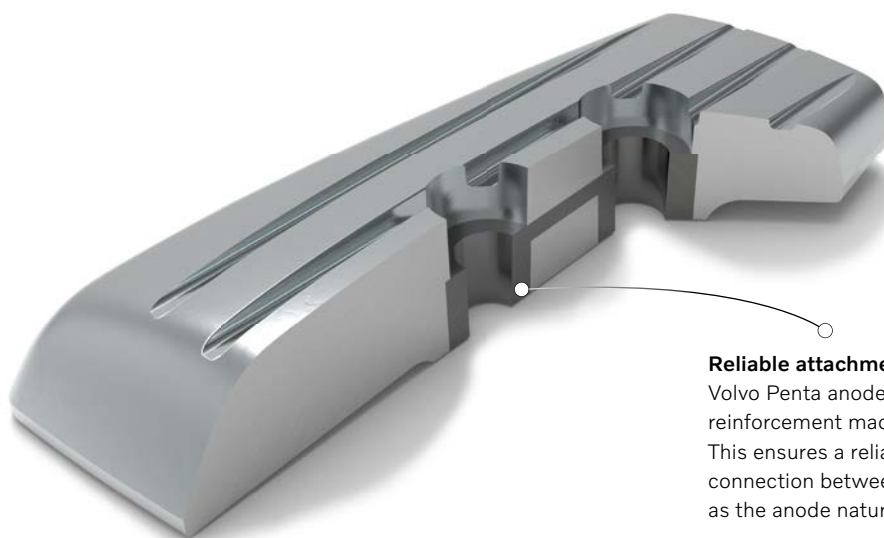

Reliable attachment for optimal protection

Volvo Penta anodes feature, when needed, an internal reinforcement made from an alloy that does not erode. This ensures a reliable attachment and electrical connection between the anode and the drive, even as the anode naturally deteriorates.

Choose the right anode

Here are our general recommendations how to choose the anode for the type of water where the boat is used:

	Salt Water*	Brackish Water*	Fresh Water
Aluminum	✓	✓	—
Magnesium	—	—	✓

* For some older drives, zinc anodes (marked with Zn) are provided for salt and brackish waters instead of aluminum anodes.

If an anode has been exposed to air for a long time, the anode can be covered by a passivating surface film that prevents it from working properly. Consider reactivating the anode by grinding it with emery paper before launching the boat.

NOTE! Do not use sandpaper, wire brush or other steel tools when cleaning, as these may damage the galvanic protection.

Factors like water flow, salinity, temperature, pollution levels and stray current considerably impact the anodes' life span.



Aquamatic Sterndrive - Single Prop Drives

Lower Gear	Salt and Brackish Water (Al*)	Fresh Water (Mg)
100 Drive	875810 (Zn)	—
200-290, SP	875815 (Zn)	876137
Spray Plate		
SX	3863193	3855412
SX-A	23164609	3888815
Transom Shield		
200-280	832598 (Zn)	873179
290, SP	3588770	3588768
SX	3586461	3855610
SX-A	23164611	3888818

Aquamatic Sterndrive - Duoprop Drives

Lower Gear	Salt and Brackish Water (Al*)	Fresh Water (Mg)
280, 290, DP	23974010	876138
Spray Plate		
DP-S, DP-SM	3863193	3855412
DPS-A, DPS-B, FWD	23164609	3888815
DPR, DPH, DPI	23520859	23520860
DPX	876638 (Zn)	
Transom Shield		
280	832598 (Zn)	873179
290, DP	3588770	3588768
DP-S, DP-SM	3586461	3855610
DPS-A, DPS-B, FWD	23164611	3888818
DPH, DPR, DPI	3588770	3588768
DPX	23813192	24042665
Exhaust Pipe		
DPH, DPI, DPR	21868042	21868041
Fork		
	23986753	23986752
Intermediate house		
DPX	24007660	3863480

S-Drives

Lower Gear	Salt and Brackish Water (Al*)	Fresh Water (Mg)
110S	875812 (Zn)	876603
120S, MS25S	23973978	876604
130S, 150S (2 piece anode)	23615636	22651247

Folding Propellers

S-Drive	Salt and Brackish Water (Al*)	Fresh Water (Mg)
2-blade & 3-blade	23974203	3858400
4-blade propeller	23974205	3584443
Shaft		
2-blade propeller	23974207	3888493
3-blade propeller (use anode for shaft mounting)	—	—
4-blade propeller	23974203	3858400

Volvo Penta IPS

	Salt, Brackish and Fresh Water
Lower Gear	3593981
Transom anode IPS1/10	23172849
Transom anode IPS15, IPS2/20, IPS3/30	23172856

* For some older drives, cadmium-free zinc anodes (marked with Zn) are provided for salt and brackish water environments instead of aluminum anodes.

V O L V O P E N T A